

MOTOVARIADORES DE DISCOS PLANETARIOS



STEPLESS SPEED MOTOR-VARIATORS

MVB Motovariadores de discos planetarios

MVB Series stepless speed motor - variators

Breve introducción

Brief introduction

Los motovariadores y motovariadores-reductores de la serie **MVB – MVB/C** son fabricados con especial tecnología avanzada lo que los hace especialmente adaptados para trabajos en la industria de manutención, cerámica, envase, embalaje, química, textil, alimentaria, máquina herramienta, líneas automáticas de producción, líneas de ensamblaje y en general en aquellas en las que se requiere una regulación de velocidad. Sus principales características son las siguientes:

- Campo de regulación continuo 1:5.3 realizado en toda la gama respecto a la velocidad de entrada.
- Constante de velocidad $\pm 0.5\%$ a la velocidad máxima y $\pm 1\%$ a la mínima.
- Sentido de giro indistinto con entrada y salida concordantes.
- Funcionamiento silencioso y uniforme, gracias al número elevado y simétrico de puntos de contacto del mecanismo de variación.
- Buen dimensionamiento para garantizar una larga duración incluso con servicio continuo y a plena carga.
- Incremento del par hasta dos veces el nominal a la velocidad mínima.
- Elevado par de arranque.
- Alto rendimiento, aproximadamente el 84% a la máxima velocidad.
- Mínima manutención.
- Facilidad de adaptación y montaje, forma coaxial, compacta y de reducidas dimensiones.
- Fabricados en aluminio de alta calidad hasta el tamaño 1.50 y en fundición el resto de modelos.

MVB – MVB/C Series of stepless speed motor-variators and motor-variators with gear reducers are developed on the basis of manufacture with advanced technologies that makes it specially adapted to work in ceramics, conveying, packing, chemical, textile, foodstuffs, machine-tools and all kinds of automatic production lines, pipelines and assembly lines which need speed-regulation. Its main features are follows:

- *Stepless variation range from 1:5.3 all ratios being reductions of the input speed.*
- *Speed uniformity $\pm 0.5\%$ at maximum speed and $\pm 1\%$ at minimum.*
- *L.h. or r.h. rotation with same direction at input and output.*
- *Silent and smooth running achieved thanks to numerous symetrically arranged points of contact in the variation mechanism.*
- *Generous dimension for extended life, also for continuous operation at full load.*
- *Torque increase of up to twice nominal torque at minimum speed.*
- *High start torque.*
- *High efficiency equal to approximately 84% at maximum speed.*
- *Minimum maintenance requeriments.*
- *Easy in adaptation, coaxial desing with compact casing and modest overall dimensions.*
- *Made of high-quality aluminium up to 1.50 size and in cast-iron for the rest of models.*

Características de funcionamiento

Structure & principle

A la máxima velocidad
At the maximum speed

A la mínima velocidad
At the minimum speed

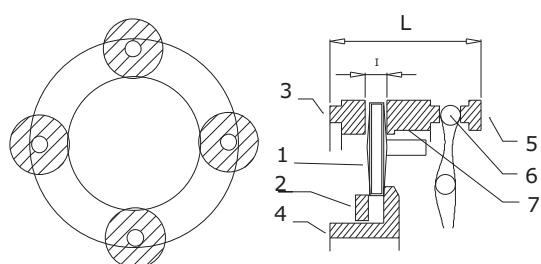
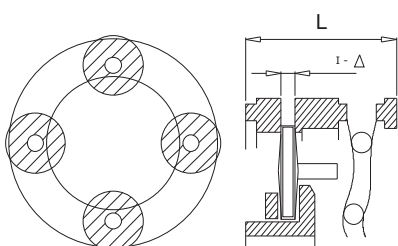

1. Satélite cónico. *Conical planet disk.*
2. Pastilla Satélites. *Friction bearings.*
3. Disco portasatélites. *Planet carrier.*
4. Pista interna. *Sun races.*
5. Discos muelle. *Belleville springs.*
6. Pista externa fija. *Fixed annulus race.*
7. Pista externa móvil. *Adjustable annulus race.*
8. Anillo porta esferas. *Ball ring.*
9. Pista externa de registro. *Cam ring.*
10. Tornillo de regulación. *Control screw.*

Designación *Designation*

1. Modelo Básico / *Basic Model*

MVB 0.75 B5.00

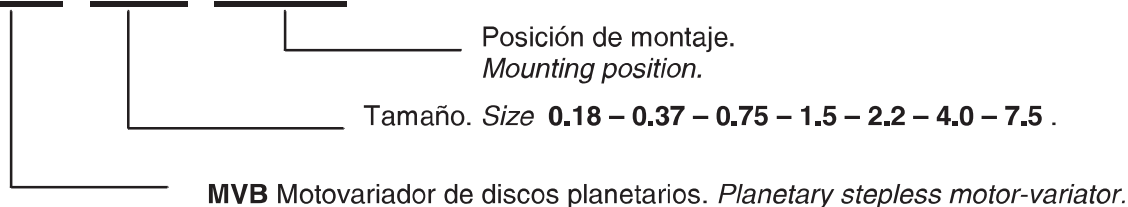

2. Modelo con reductor / *Model with gear reducer*

MVB 0.75 - 2 C 5 B5.04

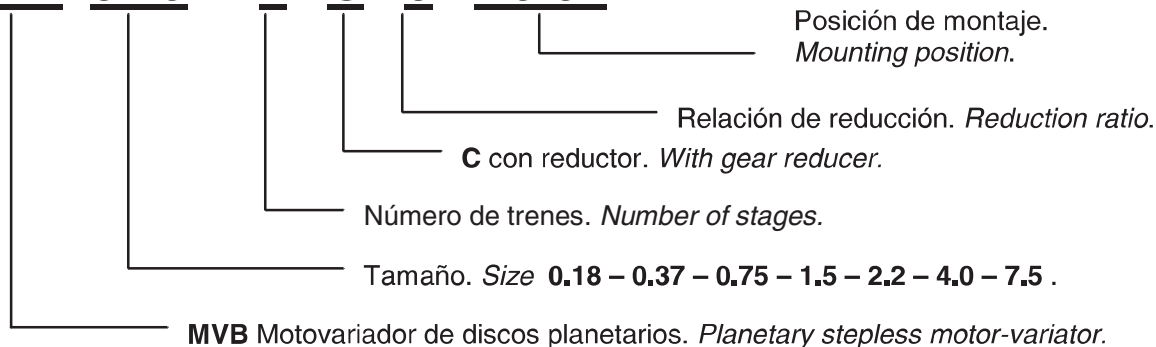

Instrucciones de montaje y mantenimiento *Operation & Maintenance*

Durante la instalación y funcionamiento deben respetarse las siguientes instrucciones:

- Se debe asegurar una buena alineación entre el eje del motor y el acoplamiento del variador. El margen de error no debe ser superior a la tolerancia admitida por el acoplamiento.
- Cuando el árbol de salida se acopla a una polea, piñón o acoplamiento elástico este debe fijarse mediante el tornillo situado en el extremo del eje o bien por calentamiento. Nunca golpear el eje de salida.
- Los variadores de velocidad mecánicos no deben usarse en aplicaciones donde se prevean sobrecargas o bloqueos de la máquina.
- La variación de velocidad debe efectuarse con el variador girando. Nunca manejar el volante de regulación con el motor parado.
- Los dos tornillos de regulación situados a ambos lados de la caja de maniobras vienen reglados de fábrica. Por favor no los toquen.
- Estos equipos están previstos para trabajar a una temperatura ambiente no superior a 40°C, se debe considerar como temperatura ambiente máxima soportable 45°C. Cuando el variador comienza a trabajar (sin carga), la temperatura se eleva más de lo normal hasta 40 –50°C por encima de la temperatura ambiente. Después de las primeras 60 – 80 horas de trabajo la temperatura disminuirá progresivamente hasta la temperatura normal de trabajo, unos 20°C por encima de la temperatura ambiente y se mantendrá estable. La sobre temperatura ocurrida en la puesta en funcionamiento no daña a ninguna de las partes del variador ni afecta al tiempo de vida del mismo. (Sugerencia: trabajar sin carga durante las primeras horas).
- El aceite lubricante usado es especial para variadores de velocidad. Su referencia es ISO VG320. Por favor comprobar el nivel de lubricante antes de su puesta en funcionamiento.



Instrucciones de montaje y mantenimiento *Operation & Maintenance*

- Los variadores se suministran con lubricante, para trabajar durante las primeras 1.000 horas, después de este periodo el lubricante debe ser reemplazado.
- El nivel de aceite debe mantenerse a un tercio de la mirilla. Comprobar el nivel con asiduidad, está estrictamente prohibido trabajar con un bajo nivel de lubricante. El tapón ciego situado en la caja de maniobras se utiliza para evitar derrame de aceite durante el transporte, debe sustituirse por un tapón desvaporizador antes de la puesta en funcionamiento.

To install and work with variators units the following instructions must be complied

- *The shaft lines should be kept concentric when the coupling is connected with a motor. The installation error should be no more than the tolerance value of the coupling.*
- *When the output shaft is installed with the coupling or belt wheel, they should be press into the screw hole on shaft end, or assembled by heating. No hammering on it.*
- *The mechanical stepless speed variator is not used in such occasion where overload or running-blockage happen to occur.*
- *Speed regulation should be effected in running. No turning the hand wheel of speed regulation when the machine stops.*
- *The banking screws of speed regulation on two ends under the operating box are well adjusted. Please don't touch them.*
- *This set is not suited to work in the environment of above 40°C, especially no more than 45°C when the temperature goes up. When the variator starts to work (without load), the temperature rises higher than normal, up to 40 – 50°C above the environment temperature. After 60 – 80 hours running, the temperature will decrease gradually. Finally, the temperature will be about 20°C higher than surrounding and keep stable. The high temperature at beginning do not damage any part of variators and do not affect its service life. (Suggestion: running without load at first.)*
- *Special liquid lubricating oil is used for the speed variator. Its ISO VG is VG320. Please check up the oil level before use.*
- *The machine is filled with lubricating oil before leaving the factory. When it stars to work up to 1000 hours for the first time, its lubricating oil should be replaced.*
- *The lubricating oil level inside the speed variator should be kept at the height of one third in the oil scale. Users should usually check up the height of oil level. It is strictly prohibited to operate it short of lubricating oil. The air crew not on the operating box is screwed up for preventing from oil leakage in moving when leaving the factory. It should be loosed when it starts to run. It is strictly forbidden to use before loosing.*

Posición estandar 1
Standard position 1

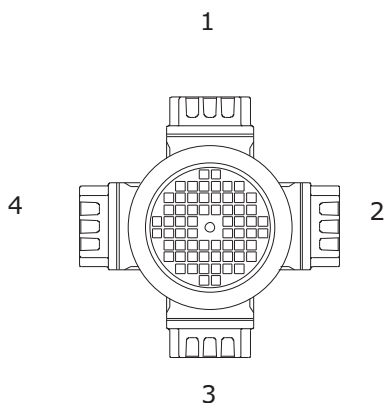

Posición de la caja de bornes
Motor terminal box position diagram

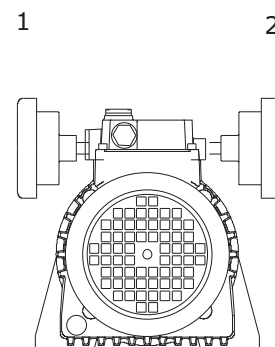

Posición del volante de mando
Hand wheel position diagram

Prestaciones de los motovariadores tipo MVB
Performance of stepless speed motor-variators type MVB

n1 = 1400 r.p.m.					
Motor KW (HP)	Tipo Type	i	Reducción Ratio	Salida	Output
				n2 r.p.m.	M2 Nm.
0.18 (0.25)	MVB 0.18		1.6 – 8.2	880 – 170	1.5 – 3
0.37 (0.50)	MVB 0.37		1.7 – 7	1000 – 200	3 – 6
0.55 (0.75)	MVB 0.75		1.7 – 7	1000 – 200	4 – 8
0.75 (1.00)	MVB 0.75		1.7 – 7	1000 – 200	6 – 12
1.10 (1.50)	MVB 1.50		1.7 – 7	1000 – 200	9 – 18
1.50 (2.00)	MVB 1.50		1.7 – 7	1000 – 200	12 – 24
2.20 (3.00)	MVB 2.20		1.7 – 7	1000 – 200	18 – 36
3.00 (4.00)	MVB 2.20		1.7 – 7	1000 – 200	24 – 48
4.00 (5.50)	MVB 4.00		1.7 – 7	1000 – 200	32 – 64
5.50 (7.50)	MVB 7.50		1.7 – 7	1000 – 200	45 – 90
7.50 (10.0)	MVB 7.50		1.7 – 7	1000 – 200	58 – 118

Prestaciones de los motovariadores-reductores compactos tipo MVB/C
Performance of motor-variators with gear reducer type MVB/C

Motor KW (HP)	Tipo Type	i	Reducción Ratio	Salida	Output
				n2 r.p.m.	M2 Nm.
0.18 (0.25) 4P n1 = 1400	MVB 0.18-C		2.5	352 – 68	3.5 – 7.4
			3.3	266 – 51.5	4.7 – 10
			5	176 – 34	7 – 15
	MVB 0.18-2C		8	110 – 21	10 – 20
			11	80 – 15.5	14 – 28
			13.3	66 – 13	17 – 34
			16.6	53 – 10	21 – 42
0.37 (0.50) 4P n1 = 1400	MVB 0.37-C		2.5	400 – 80	7.5 – 13
			3.3	300 – 60	9.5 – 20
			5	200 – 40	15 – 30
	MVB 0.37-2C		8	125 – 25	20 – 40
			11	90 – 18	28 – 56
			13.3	75 – 15	34 – 68
			16.6	60 – 12	42 – 84
0.75 (1.00) 4P n1 = 1400	MVB 0.75-C		2.5	400 – 80	15 – 29
			3.3	300 – 60	19 – 38
			5	200 – 40	30 – 60
	MVB 0.75-2C		8	125 – 25	40 – 80
			11	90 – 18	54 – 108
			13.3	75 – 15	68 – 136
			16.6	60 – 12	84 – 168
	20	50 – 10	96 – 140		



Dimensiones
Overall dimensions

Modelos básicos sin reductor
Basic models

B3

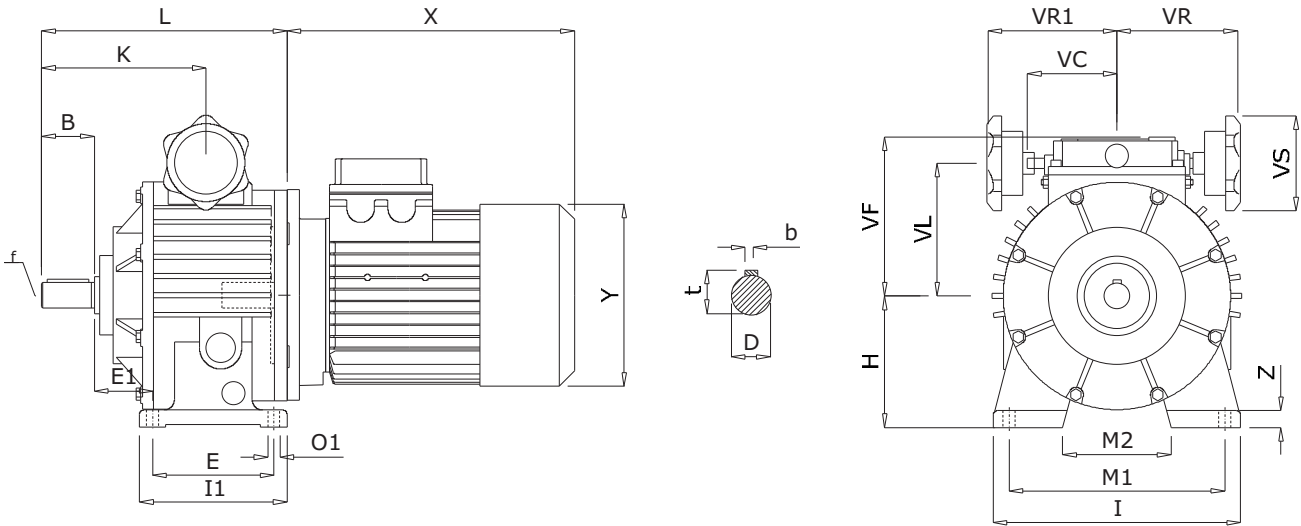

	B	D	E	E1	H	I	I1	K	L	M1	M2	O1	VC	VF	VL	VR	VR1	VS	b	f	t	X	Y	Z
MVB 0.18	23	11	105	17.5	80	145	120	87.5	135.5	110	71	9	71	111	78	110	110	85	4	-	12.5	200	120	10
MVB 0.37	30	14	104	20	93	149	125	104	140	120	96	9	71	123	90	110	110	85	5	M6	16	227	141	10
MVB 0.75	40	19	125	26	113	190	150	125.5	179	160	135	11	79	140	107	120	120	110	6	M6	21.5	268	160	15
MVB 1.50	50	24	115	53.5	123	241	150	165	238	190	143	13	-	144	122	150	-	110	8	M8	27	290	195	18
MVB 2.20	60	30	230	25	150	300	270	191	268	245	190	14	-	188	150	160	-	110	8	M8	33	320	215	25
MVB 4.00	60	30	230	25	150	300	270	191	268	245	190	14	-	188	150	160	-	110	8	M8	33	340	240	25
MVB 7.50	70	35	250	33	200	365	290	201	319	315	245	18	-	-	192	194	-	110	10	M10	38	435	275	30

B5

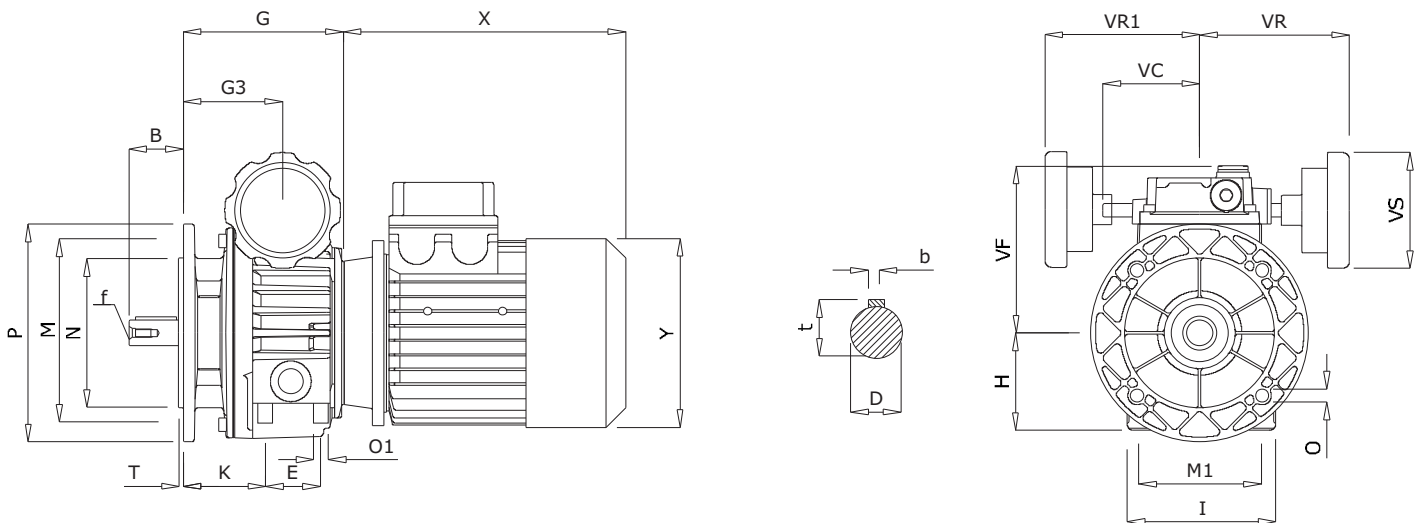

	B	D	E	G	G3	H	I	M	M1	N	P	T	K	VC	VF	VL	VR	VR1	VS	b	f	t	X	Y
MVB 0.18	23	11	50	112.5	64.5	70	72	115	60	95	140	3.5	46	71	111	78	110	110	85	4	-	12.5	200	120
MVB 0.37	30	14	40	110	74	80	90	130	77	110	160	3.5	53	71	123	90	110	110	85	5	M6	16	227	141
MVB 0.75	40	19	58	139	85.5	100	98	165	84	130	200	3.5	60	79	140	107	120	120	110	6	M6	21.5	268	160
MVB 1.50	50	24	-	188	115	126	241	165	-	130	200	3.5	-	-	144	122	150	-	110	8	M8	27	290	195
MVB 2.20	60	28	-	208	131	150	270	265	-	230	300	4	-	-	188	150	160	-	110	8	M8	31	320	215
MVB 4.00	60	28	-	208	131	150	270	265	-	230	300	4	-	-	188	150	160	-	110	8	M8	31	340	240
MVB 7.50	70	38	-	244	131	200	-	300	-	250	350	5	-	-	-	192	194	-	110	10	M10	41	435	275

Dimensiones Overall dimensions

Modelos compactos con un tren de engranajes
Model basic & one-stage gear unit

B3 PATAS / FOOT

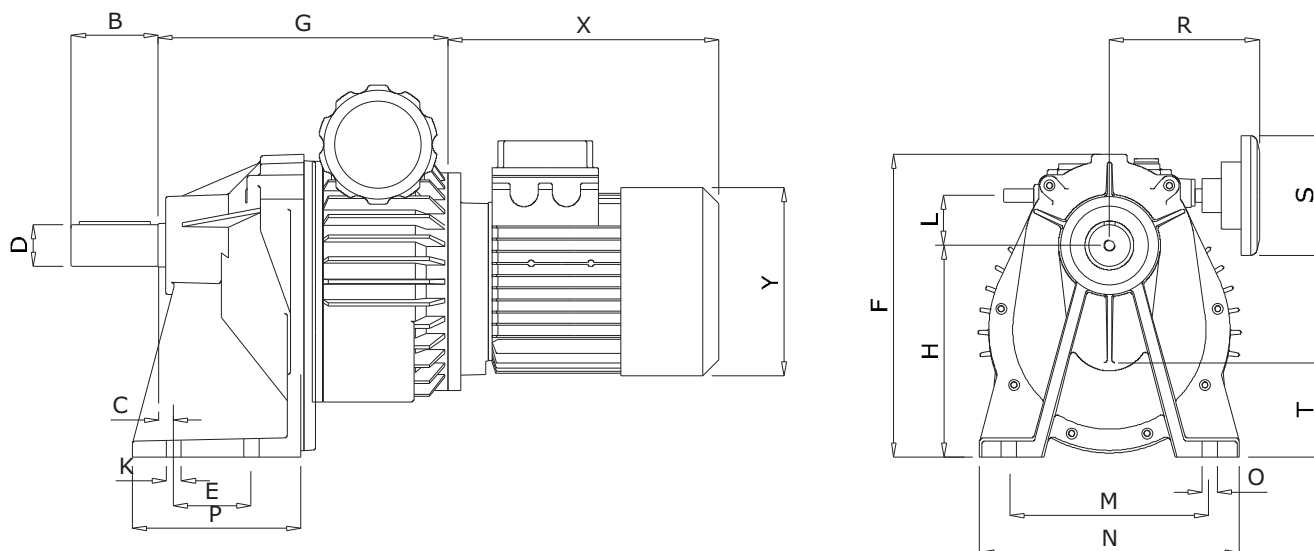

	B	C	D	E	F	G	H	Y	L	M	N	O	P	R	S	T	X	K
MVB 0.18 - C	40	18	19	45	162	189	108	120	33	115	130	9	80	110	85	66	200	16
MVB 0.37 - C	50	6	24	70	187	190	130	141	39	150	190	10	110	110	85	79	227	15
MVB 0.75 - C	60	7	28	70	228	225	160	160	46	165	210	12	130	130	110	99	268	25

B5 BRIDA / FLANGE

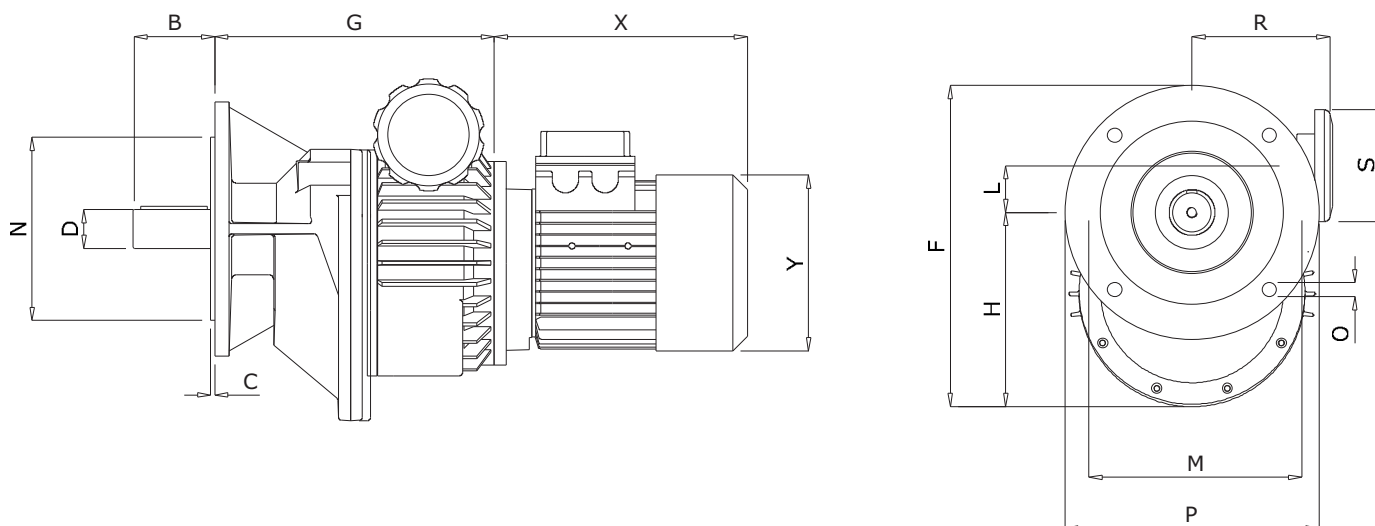

	B	C	D	F	G	H	Y	L	M	N	O	P	R	S	X
MVB 0.18 - C	40	3	19	176	191	105	120	33	115	95	9	140	110	85	200
MVB 0.37 - C	50	4	24	208	192	128	141	39	130	110	10.5	160	110	85	227
MVB 0.75 - C	60	4	28	255	227	155	160	46	165	130	12.5	200	130	110	268

Dimensiones
Overall dimensions

Modelos compactos con dos trenes de engranajes
Model basic & two-stage gear unit

B3 PATAS / FOOT

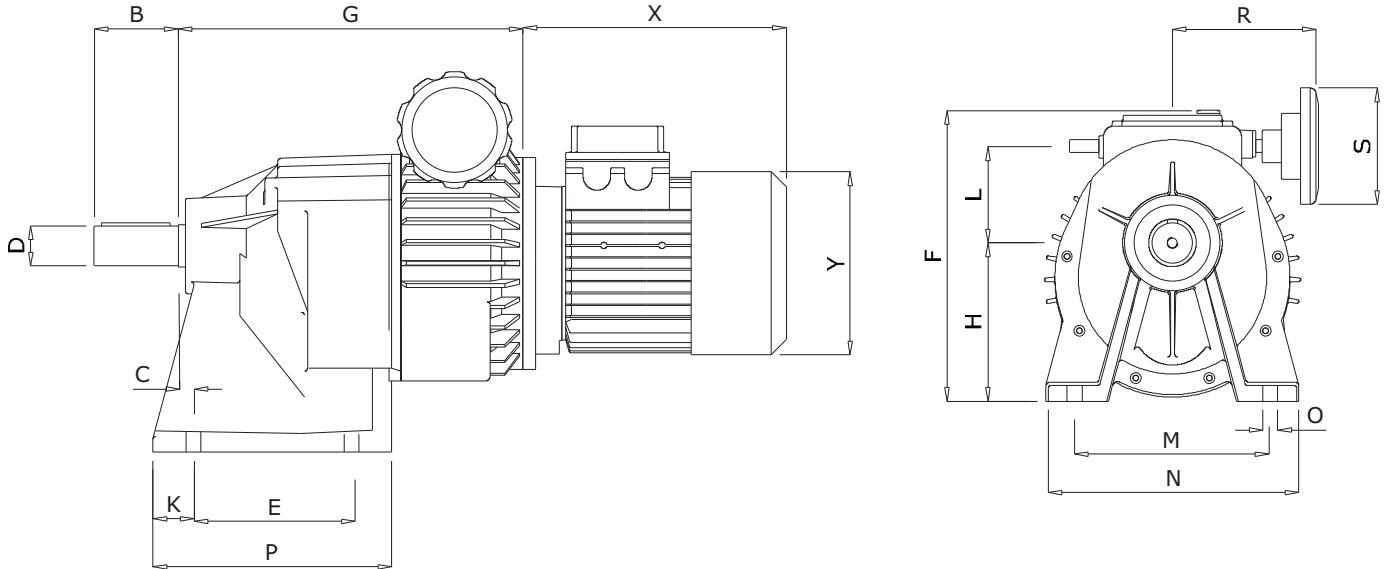

	B	C	D	E	F	G	H	Y	L	M	N	O	P	R	S	X	K
MVB 0.18 – 2C	40	27	19	70	201	229	105	120	78	105	130	9	120	110	85	200	21
MVB 0.37 – 2C	55	25	28	85	216	238	110	141	90	150	190	10	140	110	85	227	19
MVB 0.75 – 2C	65	34	32	90	261	278	154	160	107	185	230	12	150	130	110	268	21

B5 BRIDA / FLANGE

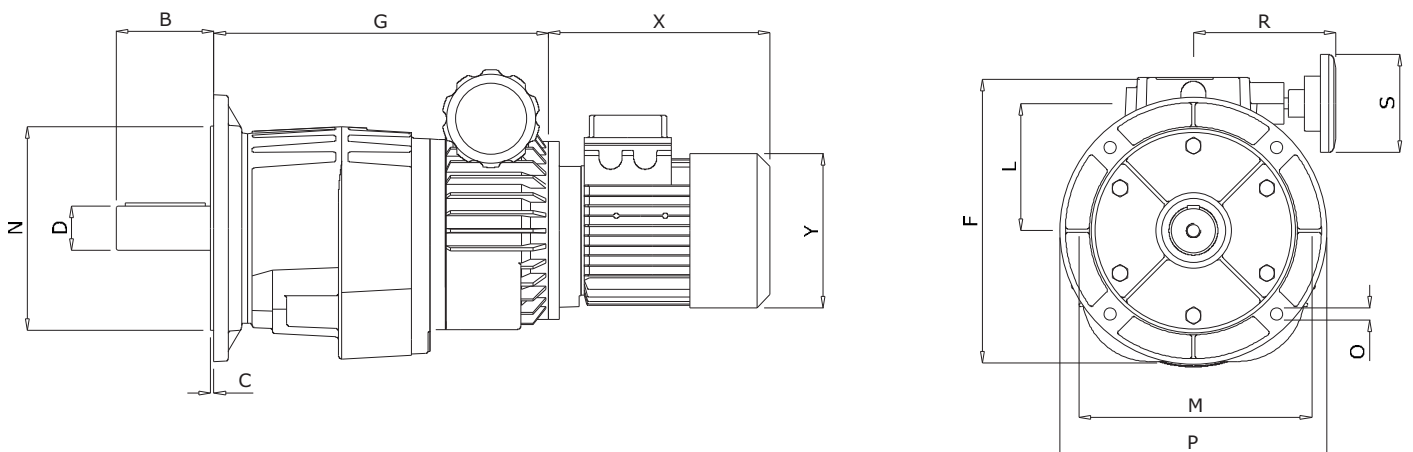

	B	C	D	F	G	Y	L	M	N	O	P	R	S	X
MVB 0.18 – 2C	40	3	19	198	231	120	78	115	95	9	140	110	85	200
MVB 0.37 – 2C	65	4	28	223	240	141	90	130	110	10.5	160	110	85	227
MVB 0.75 - 2C	65	4	32	262	280	160	107	165	130	12.5	200	130	110	268



MOTOVARIADORES - REDUCTORES DE VIS SIN FIN



MOTOR-VARIATORS & WORM GEARBOXES

MVB + MSF Motovariadores- reductores de vis sin fin

MVB + MSF Motovariator & worm gearboxes

Designación
Designation

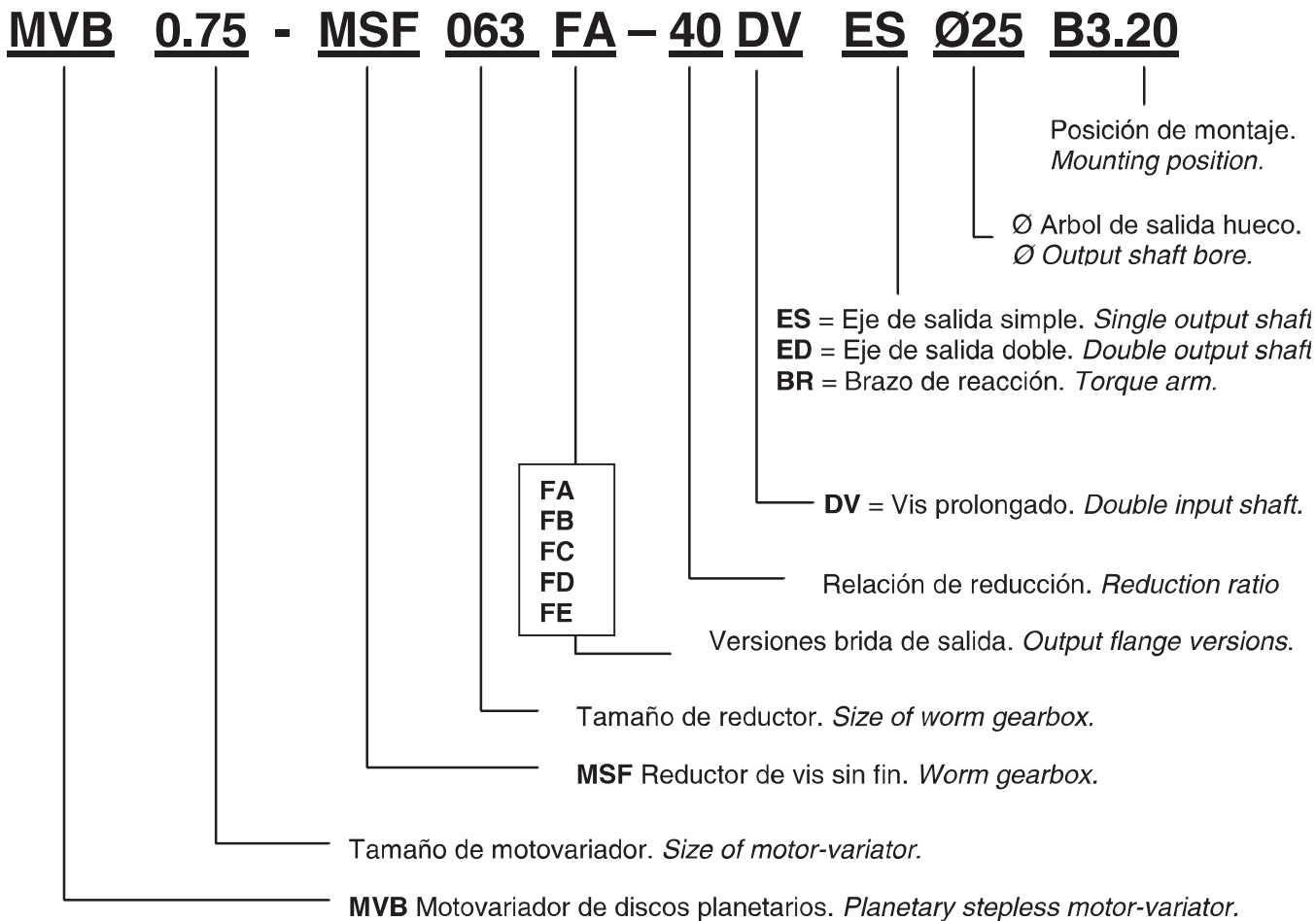

MVB + MSF Listado de combinaciones posibles

MVB + MSF Possible combinations

MSF REDUCTORES DE VIS SIN FIN / MSF WORM GEARBOXES							
MSF	40	50	63	75	90	110	130
MVB	i Reducciones / Ratios						
0.18	7.5 - 100	40 - 100					
0.37		7.5 - 80	40 - 100	50 - 100			
0.75		7.5 - 30	7.5 - 60	20 - 100	40 - 100	80 - 100	
1.5			7.5 - 30	7.5 - 40	7.5 - 60	25 - 100	80 - 100
2.2				7.5 - 15	7.5 - 30	7.5 - 60	25 - 100
4.0					7.5 - 30	7.5 - 60	25 - 100

Prestaciones de los motovariadores - reductores de vis sin fin
Performance of motor-variators & worm gearboxes

Motor Kw	n2 rpm	i	M2 Nm	Tipo Type	
0.18 4P n1= 1400	117~23	7.5	9~18	MVB 018 + MSF 040	
	88~17	10	12~23		
	59~11	15	17~32		
	44~8.5	20	22~40		
	35~6.8	25	27~47		
	29~5.7	30	30~51		
	22~4.3	40	37~62		
	18~3.4	50	22~40		
	22~4.3	40	38~63		MVB 018 + MSF 050
	18~3.4	50	44~73		
15~2.8	60	50~80			
11~2.1	80	59~82			
8.8~1.7	100	66~79			
0.37 4P n1= 1400	133~27	7.5	19~36	MVB 037 + MSF 050	
	100~20	10	25~47		
	67~13	15	36~65		
	50~10	20	46~82		
	40~8	25	55~97		
	33~6.7	30	61~107		
	25~5	40	76~124		
	20~4	50	89~120		
	25~5	40	79~134		MVB 037 + MSF 063
	20~4	50	92~155		
17~3.3	60	104~173			
12.5~2.5	80	125~173			
0.55 4P n1=1400	133~27	7.5	26~49	MVB 075 + MSF 063	
	100~20	10	34~63		
	67~13	15	48~88		
	50~10	20	62~112		
	40~8	25	75~133		
	33~6.7	30	81~146		
	25~5	40	105~179		
	20~4	50	123~207		
	20~4	50	129~216		MVB 075 + MSF 075
	17~3.3	60	146~242		
12.5~2.5	80	176~250	MVB 075 MSF 090		
12.5~2.5	80	189~309			
10~2	100	218~350			
0.75 4P n1=1400	133~27	7.5	39~73	MVB 075 + MSF 063	
	100~20	10	51~94		
	67~13	15	72~132		
	50~10	20	92~168		
	40~8	25	112~199		
	33~6.7	30	126~219		
	25~5	40	156~232		
	20~4	50	185~310		
	20~4	50	192~320		MVB 075 MSF 075
	17~3.3	60	219~300		
	17~3.3	60	230~389		MVB 075 + MSF 090
	12.5~2.5	80	265~428		
	10~2	100	303~410		
	12.5~2.5	80	302~503		MVB 075 MSF 110
10~2	100	348~575			

Motor Kw	n2 rpm	i	M2 Nm	Tipo Type	
1.10 4P n1= 1400	133~27	7.5	59~111	MVB 1.5 + MSF 075	
	100~20	10	77~144		
	67~13	15	110~203		
	50~10	20	142~258		
	40~8	25	172~308		
	33~6.7	30	195~340		
	25~5	40	245~360		
	100~20	10	78~146		MVB 1.5 + MSF 090
	67~13	15	113~208		
	50~10	20	146~266		
40~8	25	177~320			
33~6.7	30	202~356			
25~5	40	256~442	MVB 1.5 + MSF 110		
20~4	50	304~517			
20~4	50	320~550			
17~3.3	60	368~625	MVB 1.5 + MSF 130		
12.5~2.5	80	455~754			
10~2	100	522~710			
17~3.3	60	373~623	MVB 1.5 + MSF 130		
12.5~2.5	80	460~749			
10~2	100	531~868			
1.50 4P n1= 1400	133~27	7.5	78~148	MVB 1.5 + MSF 075	
	100~20	10	102~192		
	67~13	15	147~270		
	50~10	20	190~344		
	40~8	25	229~330		
	33~6.7	30	260~390		
	25~5	40	327~360		
	133~27	7.5	77~150		MVB 1.5 + MSF 090
	100~20	10	104~195		
	67~13	15	150~277		
50~10	20	194~355			
40~8	25	236~427			
33~6.7	30	270~474	MVB 1.5 MSF 110		
25~5	40	341~589			
20~4	50	406~560			
20~4	50	426~733	MVB 1.5 MSF 110		
17~3.3	60	490~833			
17~3.3	60	498~831	MVB 1.5 + MSF 130		
12.5~2.5	80	614~999			
10~2	100	696~1100			
2.2 4P n1= 1400	133~27	7.5	120~226	MVB 2.2 + MSF 110	
	100~20	10	157~294		
	67~13	15	228~418		
	50~10	20	298~549		
	40~8	25	346~664		
	33~6.7	30	413~717		
	25~5	40	533~931		
	25~5	40	542~932		MVB 2.2 + MSF 130
	20~4	50	648~1097		
	17~3.3	60	746~1246		
12.5~2.5	80	921~1499	MVB 2.2 + MSF 130		
10~2	100	1040~1100			

Dimensiones Overall dimensions

Tamaño Size		a	a1	A	K	KC	KE	KM	KN	KO	M	N	N1	O	Q	S	V	b	D	t	T
MVB 018	MSF 040	45°	45°	70	60	4	M6x8	87	60	9 (4)	75	60	36.5	6.5	55	6.5	35	6	18	20.8	26
MVB 018	MSF 050	45°	45°	80	70	5	M8x10	90	110	11 (4)	85	70	43.5	8.5	64	7	40	8	25	28.3	30
MVB 037																					
MVB 037	MSF 063	45°	45°	100	85	6	M8X14	150	115	11 (4)	95	80	53	8.5	80	8	50	8	25	28.3	36
MVB 075																					
MVB 037	MSF 075	45°	45°	120	90	6	M8X14	165	130	14 (4)	115	95	57	11	93	10	60	8	28	31.3	40
MVB 075																					
MVB 1.5																					
MVB 075	MSF 090	45°	45°	140	100	6	M10X18	175	152	14 (4)	130	110	67	13	102	11	70	10	35	38.3	45
MVB 1.5																					
MVB 1.5	MSF 110	45°	45°	170	115	6	M10X18	230	170	14 (8)	165	130	74	14	125	14	85	12	42	45.3	50
MVB 2.2																					
MVB 4.0																					
MVB 1.5	MSF 130	45°	22.5°	200	120	6	M12X21	255	180	16 (8)	215	180	81	16	140	15	100	14	45	48.8	60
MVB 2.2																					
MVB 4.0																					

Tamaño Size		C	E	F	G	G1	G3	H	I	KA	KB	KP	KQ	L	P	R	VF	VL	VS	VR	VR1							
MVB 018	MSF 040	100	121.5	43	183	78	135	50	40	67	7	110	95	71	87	71.5	151	118	85	110	110							
MVB 018	MSF 050	120	144	49	193	92	145	60	50	90	9	125	110	85	100	84	161	128	85	110	110							
MVB 037																						190	154	173	140	85	110	110
MVB 037	MSF 063	144	174	67	205	112	169	72	63	82	10	180	142	103	110	102	186	153	85	110	110							
MVB 075																						234	181	203	170	110	120	120
MVB 037	MSF 075	172	205	72	223	120	187	86	75	111	13	200	170	112	140	119	198	165	85	110	110							
MVB 075																						252	198	215	182	110	120	120
MVB 1.5																						301	228	219	197	110	150	-
MVB 075	MSF 090	208	238	74	269	140	215	103	90	111	13	210	200	130	160	135	230	197	110	120	120							
MVB 1.5																						318	245	234	212	110	150	-
MVB 1.5	MSF 110	252.5	295	-	348	155	275	128	110	131	15	280	260	144	200	168	254	232	110	150	-							
MVB 2.2																						368	291	298	260	110	160	-
MVB 4.0																						368	291	298	260	110	160	-
MVB 1.5	MSF 130	292.5	335	-	368	170	295	148	130	140	15	320	290	155	250	188	274	252	110	150	-							
MVB 2.2																						388	311	318	280	110	160	-
MVB 4.0																						388	311	318	280	110	160	-

Posibilidad de bridas y ejes huecos especiales. Ver dimensiones en la página 13.
Possibility of special flanges and bore shafts. See dimensions on page 13.

